

240V 600mm EPIC LED Batten

Installation & Maintenance Instruction Leaflet

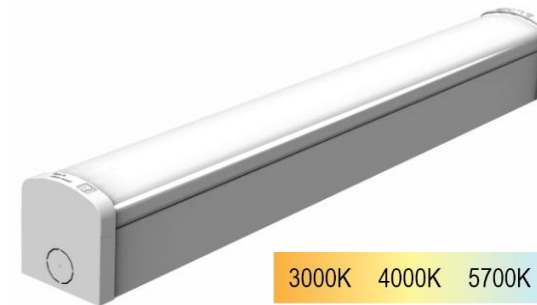

Victoria (Head Office & Manufacturing)

Website: www.clevertronics.com.au

Email: info@clevertronics.com.au

Phone: +61 3 9559 2700

Fax: +61 3 9559 2799

New South Wales

Phone: +61 2 8805 6400

Fax: +61 2 8805 6444

Queensland

Phone: +61 7 3442 9700

Fax: +61 7 3442 9777

South Australia/Northern Territory

Phone: +61 8 8301 8800

Fax: +61 8 8351 8286

Western Australia

Phone: +61 8 9207 0000

Fax: +61 8 9207 0088

New Zealand

Phone: +64 800 548 448

Designed in Australia to comply with the requirements of AS/NZS CISPR15: 2017

Models: EPIC-600-xx

Options:

Microwave Sensor (HI/LO) xx = SEN

Spare Parts:

1330086-B LED Driver - 20w Stallion E-MNT

1330087-B LED Driver - 20w Stallion E-MNT,MS-HL (SEN version only)

Important:

It is illegal for anyone, except for a licensed electrician to install or maintain this product. Before installation, ensure that the electricity supply has been switched off and isolated. Installation must be carried out in accordance with the relevant Australian and International Standards.

Installation:

This product can be mounted to any solid surface. Please follow the below installation steps:

- Refer Images below for the mounting hole and cable access.
- Remove the diffuser by leveraging a flat head screwdriver into the provided slot (A). This is to be done on the end marked "Open this end". Once the endcap is unclipped hinge it away from the diffuser until a click is heard. Undo the diffuser securing screw (B), lift diffuser away from body (C).
- Disconnect the LED strip connector. If connected unhook the lanyard
- Position the batten in the desired location.
- Mark out the fixing points on the mounting surface.
- Install appropriate fixing hardware.
- Route power supply cables through the access hole as the rear of the fitting or the ends if using surface conduit (punch out the knock-outs in the plastic end caps)
- Fasten the batten to the surface.
- Terminate the supply cable to the terminals marked L, N and E (240V AC/50Hz)
- Set Colour Switch to the desired colour (3000K, 4000K, 5700K)
- Attach the diffuser to lanyard, Re-connect the LED strip connector.
- Re-install the diffuser, Tighten diffuser screw (B) and close endcap clip (A).

NOTE:

This luminaire (with reinforced insulation between control/LED terminal and AC Supply) contains non-user replaceable light source – to be replaced (if required) by the manufacturer or his service agent or a similar qualified person.

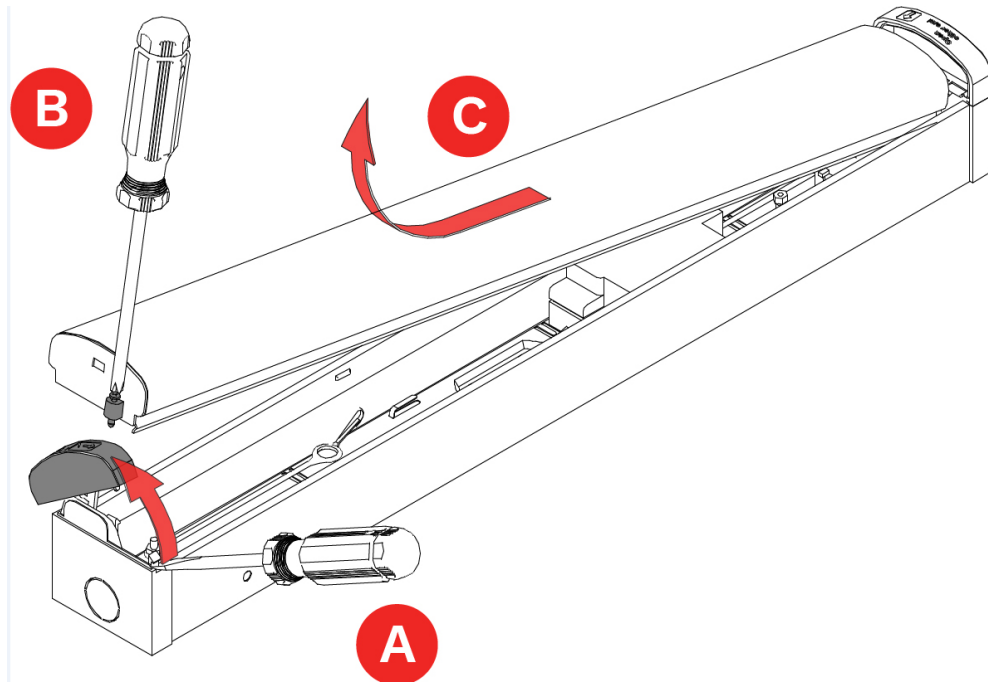

Dimensions:

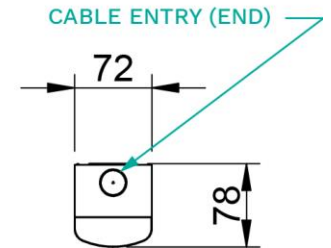
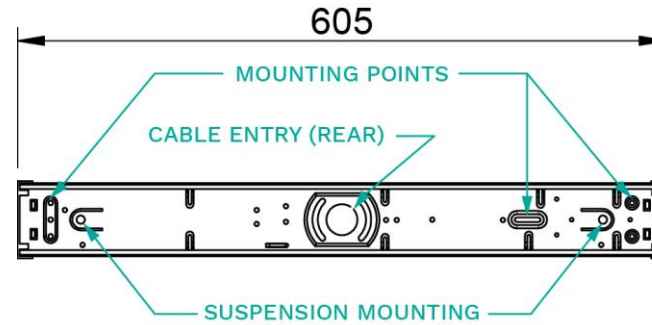

Colour Setting:

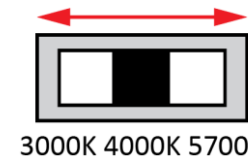

3000K 4000K 5700K

Trouble Shooting:

Below are a list of common problems and their possible causes.

Fault: The LED Strip is not illuminated.

Check: A.C. is connected and is turned on.

Wiring connections between the LED Driver & LED Strips

Warranty:

For Product Warranty information and Terms and Conditions of Sales please refer to our website

<http://clevertronics.com.au/terms-conditions-sale-australia-nz/>